

# Demodulation Performance Assessment of New GNSS Signals in Urban Environments

M. Roudier, *CNES*

A. Garcia-Pena, O. Julien, *ENAC*

T. Grelier, L. Ries, *CNES*

C. Poulliat, M-L. Boucheret, *ENSEEIH*T

D. Kubrak, *Thales Alenia Space*

## BIOGRAPHIES

**Marion Roudier** graduated from ENAC (the French civil aviation school) with an engineer diploma in 2011. She is now a PhD student at ENAC and studies improved methods/algorithms to better demodulate the GPS signals as well as future navigation message structures. Her thesis is funded by CNES (Centre National d'Etudes Spatiales) and Thales Alenia Space.

**Axel Garcia-Pena** is a researcher/lecturer with the SIGNAL processing and NAVigation (SIGNAV) research group of the TELECOM lab of ENAC (French Civil Aviation University), Toulouse, France. His research interests are GNSS navigation message demodulation, optimization and design, GNSS receiver design and GNSS satellite payload. He received his double engineer degree in 2006 in digital communications from SUPAERO and UPC, and his PhD in 2010 from the Department of Mathematics, Computer Science and Telecommunications of the INPT (Polytechnic National Institute of Toulouse), France.

**Olivier Julien** is with the head of the SIGNAL processing and NAVigation (SIGNAV) research group of the TELECOM lab of ENAC (French Civil Aviation University), Toulouse, France. His research interests are GNSS receiver design, GNSS multipath and interference mitigation, and interoperability. He received his engineer degree in 2001 in digital communications from ENAC and his PhD in 2005 from the Department of Geomatics Engineering of the University of Calgary, Canada.

**Thomas Grelier** has been a radionavigation engineer at CNES since 2004. His research activities focus on GNSS signal processing and design, development of GNSS space receivers and radiofrequency metrology sensor for satellite formation flying. He graduated from the French engineering school Supélec in 2003 and received a M.S. in electrical and computer engineering from Georgia Tech (USA) in 2004.

**Lionel Ries** is head of the localization / navigation signal department in CNES, the French Space Agency. The department activities cover signal processing, receivers and payload regarding localization and navigation

systems including GNSS (Galileo, GNSS space receivers), Search & Rescue by satellite (SARSAT, MEOSAR), and Argos (Environment Data Collect and Location by Satellite). He also coordinates for CNES, research activities for future location / navigation signals, user segments equipment and payloads.

**Charly Poulliat** received the Eng. degree in Electrical Engineering from ENSEA, Cergy-Pontoise, France, and the M.Sc. degree in Signal and Image Processing from the University of Cergy-Pontoise, both in June 2001. From Sept. 2001 to October 2004, he was a PhD student at ENSEA/University Of Cergy-Pontoise/CNRS and received the Ph.D. degree in Signal Processing for Digital Communications from the University of Cergy-Pontoise. From 2004 to 2005, he was a post-doctoral researcher at UH coding group, University of Hawaii at Manoa. In 2005, he joined the Signal and Telecommunications department of the engineering school ENSEA as an Assistant Professor. He obtained the habilitation degree (HDR) from the University of Cergy-Pontoise in 2010. Since Sept. 2011, he has been a full Professor with the National Polytechnic Institute of Toulouse (University of Toulouse, INP-ENSEEIH)T). His research interests are signal processing for digital communications, error-control coding and resource allocation.

**Marie-Laure Boucheret** received the Eng. degree in Electrical Engineering from ENST Bretagne, Toulouse, France, and the M.Sc. degree in Signal Processing from the University of Rennes, both in June 1985. In June 1997, she received the Ph.D. degree in Communications from TELECOM ParisTech, and the habilitation degree (HDR) in June 1999 from INPT University of Toulouse. From 1985 to 1986 she has been a research engineer at the French Philips Research Laboratory (LEP). From 1986 to 1991, she has been an engineer at Thales Alenia Space, first as a project Engineer (TELECOM II program) then as a study engineer at the transmission laboratory. From 1991 to 2005 she was an Associated Professor then a Professor at TELECOM ParisTech. Since March 2005 Marie-Laure Boucheret is a Professor at the National Polytechnic Institute of Toulouse (University of Toulouse, INP-ENSEEIH)T). She is also with the Signal and Communication group of the IRIT Laboratory.

**Damien Kubrak** graduated in 2002 as an electronics engineer from ENAC in Toulouse, France. He receives his Ph.D from ENST Paris, France in 2007. He joined Thales Alenia Space France in 2006 where he has been in charge of land vehicle navigation, GNSS/INS hybridization and indoor positioning. He is currently user segment technical manager and focuses on software receiver, filtering techniques and accurate time transfer.

## ABSTRACT

Satellite navigation signals demodulation performance is historically tested and compared in the Additive White Gaussian Noise propagation channel model which well simulates the signal reception in open areas. Nowadays, the majority of new applications targets dynamic users in urban environments; therefore the GNSS signals demodulation performance has become mandatory to be provided in urban environments. The GPS L1C signal demodulation performance in urban environments is thus provided in this paper. To do that, a new methodology adapted to provide and assess GNSS signals demodulation performance in urban channels has been developed. It counteracts the classic method limitations which are the fluctuating received  $C/N_0$  in urban environments and the fact that each received message is taken into account in the error rate computation whereas in GNSS it is not necessary. The new methodology thus proposes to provide the demodulation performance for 'favorable' reception conditions together with statistical information about the occurrence of these favorable reception conditions. To be able to apply this new methodology and to provide the GPS L1C signal demodulation performance in urban environments, a simulator SiGMeP (Simulator for GNSS Message Performance) has been developed. Two urban propagation channel models can be tested: the narrowband Perez-Fontan/Prieto model and the wideband DLR model. Moreover, the impact of the received signal phase estimation residual errors has been taken into account (ideal estimation is compared with PLL tracking).

## INTRODUCTION

The majority of new GNSS applications takes place in urban environments. In these obstructed environments, the received signal is severely impacted by obstacles which induce fading of the resulting received signal that is detrimental to both the ranging and demodulation capability of the receiver. The GNSS signals demodulation performance is thus degraded in urban environments compared against the one obtained in the Additive White Gaussian Noise (AWGN) propagation channel model. Since the first GNSS signals were developed in an open environment context, the AWGN propagation channel model was adapted to provide their demodulation performance. However nowadays satellite navigation is more and more used in cities and constrained environments. Indeed the recently developed modernized GNSS signals have taken into account this

new constraint in their design. The current and future GNSS signals demodulation performance thus need to be assessed in an urban propagation channel.

The current and future GNSS signals demodulation performance in urban environments is provided in this paper through simulations. In fact, the use of a simulator allows getting away from dependence of real signals availability, controlling the simulation parameters and testing new configurations. In that sense, the simulator SiGMeP has been developed. This simulator allows calculating the current and future GNSS signals demodulation performance as faithful to the reality as possible due to the implementation of realistic urban propagation channel and receiver models.

Moreover, since the urban propagation channel is very different from the AWGN propagation channel, it is necessary to adapt the methodology of representing the GNSS signals demodulation performance in these environments. A new methodology is thus proposed in this paper consisting in two main parts: first, the introduction of a new figure of merit better representing the GNSS specific characteristics with respect to a classic communication system than the usual BER/WER curve as a function of the signal  $C/N_0$ , and second, the choice of the direct  $C/N_0$  before channel propagation attenuation instead of the instantaneous received  $C/N_0$ .

The first part describes the SiGMeP simulator and the two propagation channel models used to model an urban environment: the urban narrowband Perez-Fontan/Prieto model and the urban wideband DLR model. The second part of the paper describes in detail the new methodology developed to provide a demodulation performance figure of merit adapted to the GNSS specific characteristics in an urban environment. Finally, the results obtained with this new methodology when using SiGMeP are presented.

## I- THE SIGMEP SIMULATOR DESCRIPTION

The SiGMeP simulator (further descriptions in [1][2]) is a C language-software which simulates a GNSS signal transmission-reception chain (see Figure 1), from the message generation to the decoding process and demodulation performance computation.

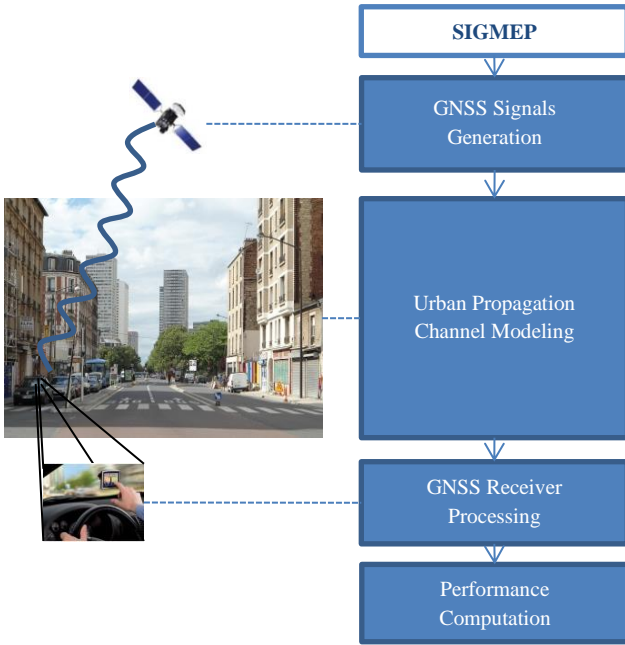

**Figure 1:** Simulation of a GNSS signal transmission/reception chain by SiGMeP

### 1) GPS L1C Signal Generation

Only the GPS L1C signal is generated by SiGMeP in this work. The GPS L1C navigation message (defined in [3]) consists of a continuous flow of frames and each frame is divided into 3 subframes. Subframe 1 is formed by 9 information bits and provides the Time Of Arrival (TOI). Subframe 2 is formed by 600 information bits: 576 bits of non-variable data and 24 Cyclic Redundancy Check (CRC) bits. The data are non-variant over a period of multiple frames and provide Clock errors correction and Ephemeris Data (CED). Subframe 3 is formed by 274 information bits: 250 bits of variable data and 24 CRC bits. Figure 2 illustrates the GPS L1C message structure.

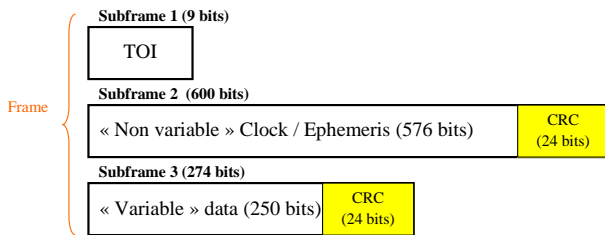

**Figure 2:** GPS L1C data message description

The subframe 1 is encoded by a BCH (Bose, Ray-Chaudhuri and Hocquenghem) channel code resulting into 52 coded bits.

Subframes 2 and 3 are encoded by a Low-density parity-check (LDPC) channel code with code rate equal to  $\frac{1}{2}$  resulting into 1200 and 548 coded bits respectively. The L1C standard [3] specifies a (1200, 600) systematic irregular LDPC code for subframe 2 and a (548, 274) systematic irregular LDPC code for subframe 3. The LDPC codes for subframes 2 and 3 are different because

of their different lengths. Finally, the 1748 coded bits are interleaved by a block interleaver of 38 lines and 46 columns. The resulting frame consists of 1800 coded bits modulated with a TMBOC(6,1) modulation (equivalent to a BPSK modulation for demodulation purposes). The resulting 1800 symbols are transmitted at 100 sps and the entire GPS L1C navigation message thus lasts 18s.

The GPS L1C signal is divided into two components: the data and the pilot component. The power dedicated to the data component is  $\frac{1}{4}$  of the transmitted signal total power and  $\frac{3}{4}$  for the pilot component.

The mathematical expression of emitted GPS L1C signal can be modelled as:

$$s(t) = \sqrt{\frac{1}{4}} C_{data}(t) D(t) e^{j2\pi L_1 t} + \sqrt{\frac{3}{4}} C_{pilot}(t) e^{j2\pi L_1 t} \quad (1)$$

where:

- $C_{data}(t)$  and  $C_{pilot}(t)$  are the spreading codes (including the spreading waveform),
- $D(t)$  is the data stream,
- $L_1 = 1575.42$  MHz is the carrier frequency.

### 2) Urban Propagation Channel Models

The propagation channel model is then simulated by SiGMeP. Three choices are offered: the AWGN, the narrowband Perez-Fontan/Prieto and the wideband DLR channel models.

#### 2) a. Channel Impulse Response

The received signal  $r$  after its transmission through the propagation channel can be linked to the emitted signal  $s$  by the channel impulse response  $h$ :

$$r(t) = \int_{-\infty}^{+\infty} h(t; \tau) s(t - \tau) d\tau \quad (2)$$

Where  $h$  mathematical expression is different for each propagation channel model type:

- Narrowband: the Perez-Fontan/Prieto model

$$h(t; \tau) = c(t) \delta(t - \tau_{direct}(t)) \quad (3)$$

where:

- $c(t) = a_{direct}(t) e^{j\phi_{direct}(t)} + a_{mult}(t) e^{j\phi_{mult}(t)}$  is the complex envelope of the overall received signal (corresponding to the propagation channel impact),

- $\tau_{direct}$  is the Line-Of-Sight (LOS) propagation time,
- $a_{direct}$  is the direct signal component amplitude and  $\varphi_{direct}$  is its Doppler phase,
- $a_{mult}$  is the multipath component amplitude and  $\varphi_{mult}$  is its phase.

The direct signal component corresponds to the LOS signal which can be potentially shadowed or blocked. The multipath component corresponds to the sum of all the reflections/refractions of the transmitted signal found at the RF block output.

➤ **Wideband:** the DLR model

$$h(t, \tau) = c_{direct}(t)\delta(\tau - \tau_{direct}(t)) + \sum_{l=1}^L c_l(t)\delta(\tau - \tau_l(t)) \quad (4)$$

where:

- $c_{direct} = a_{direct}(t)e^{j\varphi_{direct}(t)}$  is the complex envelope of direct signal component; representing the propagation channel impact on the direct component,
- $\tau_{direct}$  is the propagation time,
- $L$  is the number of echoes,
- $c_l = a_l(t)e^{j\varphi_l(t)}$  is the complex envelope of the  $l$ th echo,
- $\tau_l$  is the delay between the direct signal component and the  $l$ th echo.

**2) b. Narrowband: the Prieto Model**

The Perez-Fontan/Prieto propagation channel model has been firstly designed by F. Perez-Fontan in the early 2000 [4][5]. Several evolutions have been then implemented by Prieto [6]. The final model is presented here.

**Loo Distribution**

This model is a statistical model based on measurement campaigns carried out in the 90s. The measurement campaigns allowed modeling the received signal complex envelope  $c(t)$  behavior with a Loo distribution.

The distribution of the Loo parameters is defined as follows [4]:

- The amplitude of the direct signal component  $a_{direct}(t)$  follows a Log-Normal distribution, characterized by its mean  $M_A$  and its standard deviation  $\Sigma_A$ ,
- The amplitude of the multipath component  $a_{multipath}(t)$  follows a Rayleigh distribution, with a standard

deviation  $\sigma$ . The value of  $\sigma$  is calculated from the average multipath power with respect to an unblocked LOS signal:  $MP_{dB}$  (5).  $MP_{dB}$  is the parameter provided in the literature.

$$\sigma = \sqrt{10^{-MP_{dB}/10} / 2} \quad (5)$$

Therefore, the set of parameters ( $M_A$ ,  $\Sigma_A$ ,  $MP_{dB}$ ) completely defines the Loo distribution and is referred as the Loo parameters.

The Loo parameters are random variables. Each Loo parameter distribution is described in Table 1.

**Table 1:** Loo parameters generation

$M_A \sim \text{Gaussian}(\mu_1, \sigma_1)$	$\mu_1$ is fixed, depending on environmental conditions
	$\sigma_1$ is fixed, depending on environmental conditions
$\Sigma_A \sim \text{Gaussian}(\mu_2, \sigma_2)$	❖ $\mu_2 = a_1 * M_A^2 + a_2 * M_A + a_3$
	❖ $a_1, a_2, a_3$ are fixed, depending on environmental conditions
	❖ $\sigma_2 = b_1 * M_A^2 + b_2 * M_A + b_3$
	❖ $b_1, b_2, b_3$ are fixed, depending on environmental conditions
$MP \sim \text{Gaussian}(\mu_3, \sigma_3)$	$\mu_3$ is fixed, depending on environmental conditions
	$\sigma_3$ is fixed, depending on environmental conditions

The Loo parameter distribution parameters are provided in [6] and depend on the environmental conditions:

- The type of environment (semi-urban, urban, deep urban...),
- The satellite elevation angle,
- The signal carrier band,
- The channel states.

The generation of the received signal complex envelope samples following a Loo distribution for the Prieto channel model is illustrated in Figure 3, with the Loo generator described in further publications [1].

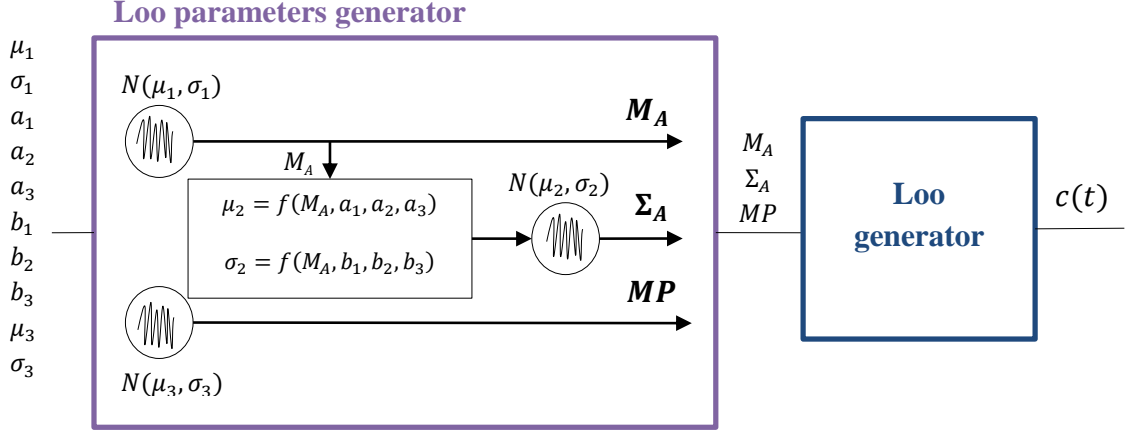

**Figure 3:** Loo parameters generation

## 2-States Model

The Perez-Fontan/Prieto model classifies the received signal into two states [6], according to the impact level of the propagation channel.

More specifically, each state corresponds to a particular environment impact, representative to the strength of the shadowing/blockage effect on the received direct signal component:

- “Good” for LOS to moderate shadowing, and
- “Bad” for moderate to deep shadowing.

Therefore, each state has associated a different set of Loo parameters for a fixed type of environment, a fixed satellite elevation angle and a fixed signal carrier band.

The state transitions are dictated by a semi-Markov model [6]: we directly move from one state to the other, the duration of each state being defined by a statistical law. Reference [6] suggests that the duration of each state follows a Log-Normal distribution, whatever the state Good or Bad. The parameters of the Log-Normal distribution depend on the propagation environment. The database used in this paper to determine the Log-Normal parameters has been extracted from [6].

## Slow and Fast Variations

The two signal components constituting the received signal (3) have different variation rates. In other words, the minimum length (or time if converting the length by using the user velocity) between two uncorrelated samples of a component is different for each component. The direct signal component variation rate is slower than the multipath component variation rate.

For a Log-Normal variable corresponding to the direct signal component, the minimum length separating two uncorrelated samples is referred to as the correlation distance  $l_{corr}$ . The correlation distance is equal to 1 meter for S-band and 2 meters for L-band according to [6].

For the Rayleigh variables corresponding to the multipath component, variables are generated at least  $\lambda/8$  meters [5] and are filtered by a Doppler filter with a cut-off frequency equal to the received signal Doppler spread  $B_d$  [6].  $B_d$  represents the bandwidth occupied by the different Doppler shifts of each multipath component. The Doppler spread of the channel is defined by this expression [7]:

$$B_D = \frac{vf_c}{c} \quad (6)$$

where:

- $v$  is the user speed (in m/s),
- $f_c$  is the carrier frequency,
- $c = 3 \cdot 10^8$  m/s is the speed of light.

The Doppler filter suggested by [6] is a Butterworth filter, more realistic than a Jakes filter conventionally used.

$$|H_{Butt}(f)|^2 = \frac{A}{1 + \left(\frac{f}{f_{cut}}\right)^{2k}} \quad (7)$$

where:

- $k$  is the filter order,
- $f_{cut} = B_D$  is the cut-off frequency,
- $A$  is a constant used to force the overall filter energy equal to one so that the standard deviation of the complex Gaussian process is not changed after filtering.

## 2) c. Wideband: the DLR Model

The propagation channel model described in this section is wideband, contrary to the previous propagation channel model (Prieto based on Perez-Fontan) which is narrowband. The difference lies in the multipath

component modeling. On one hand, in the Prieto channel model, all the components are considered to be received at the same instant of time, the multipath echoes being added among them, resulting into a Rayleigh Distribution, and added to the LOS component as well. In this way, the time delay between the LOS and each multipath echo is not represented and the resulting received component follows a Loo distribution. On the other hand, in the DLR propagation channel model, the time delay between the LOS component and each multipath echo is modeled (4): each component is considered separately. Indeed, the DLR model targets satellite navigation systems and has been specially designed in order to study the multipath effect in GNSS receivers [8].

In order to provide the impulse response of the propagation channel, the DLR model generates an artificial scenario representing the characteristics of a given urban environment (see Figure 4) where a user can move, with potential obstacles to the received signal: buildings, trees, lampposts and reflectors [9][10]. These obstacles are statistically generated but the attenuation, the phase and the delay associated to the LOS and multipath components are partly deterministically determined by ray tracing and geometric techniques. Furthermore, the number of echoes and their life span are statistical variables depending on the satellite elevation.

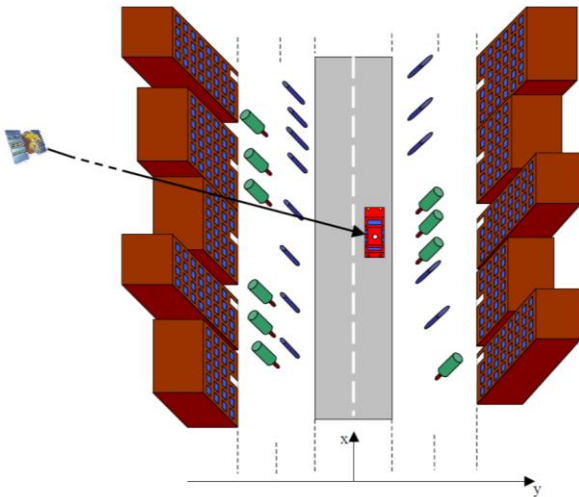

**Figure 4:** Scene example generated by the DLR propagation channel model [9]

The generation of this scenario, the characterization of its obstacles and, in summary, the design of a wideband model [11] being partly deterministic partly statistic, was possible thanks to a high delay resolution measurement campaign launched by the DLR in 2002 [12]. This model is freely accessible on the DLR website.

### 3) Phase Estimation

In SiGMeP, the received signal phase can change very quickly because of the urban propagation channel impact. In this context, assuming perfect carrier phase estimation,

as it is usually done in AWGN channels, it does not faithfully represent the reality. Thus, a realistic phase estimation process is considered: a PLL phase tracking. Nevertheless, in order to investigate the PLL impact on the demodulation performance, ideal phase estimation can be selected in SiGMeP to be compared with the PLL tracking.

#### 3) a. Ideal Phase Estimation

For the narrowband Perez-Fontan/Prieto channel model, if ideal phase estimation is considered, each sample is compensated by the channel model phase exact value.

$$\varphi_{ideal}[k] = phase\{c[k]\} \quad (8)$$

Whereas for the wideband DLR channel model, each sample is compensated by a channel model phase resulting value defined by the following expression:

$$\varphi_{ideal\ resulting}[k] = phase\left\{\sum_{l=1}^L \frac{R(\tau_k[l])}{N} * a_k[l] * e^{j\varphi_k[l]}\right\} \quad (9)$$

where:

- $L$  is the number of echoes,
- $R[.]$  is the autocorrelation function of the spreading code,
- $c_k[l] = a_k[l]e^{j\varphi_k[l]}$  is the multipath component impact associated with the  $l$ th echo for the sample  $k$ ,
- $\tau_k[l]$  is the delay between the direct signal component and the  $l$ th echo for the sample  $k$ .

#### 3) b. PLL Phase Estimation

In a GNSS receiver, the received signal phase is estimated by using a PLL. In SiGMeP, a PLL has thus been implemented to faithfully represent the real GNSS receiver process. Moreover, in order to detect whether the PLL is locked or not, a PLL phase lock detector has also been added.

#### PLL

The PLL in SiGMeP is controlled by the correlator outputs values provided by the pilot component (see Figure 5).

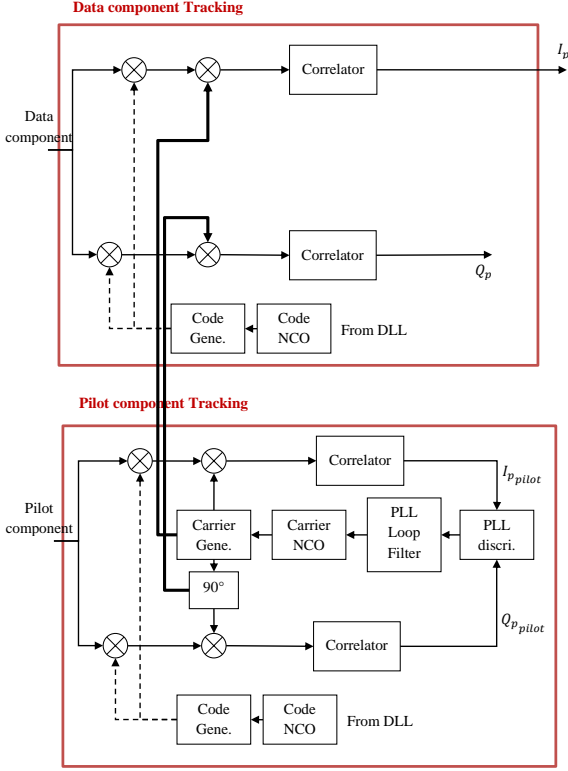

**Figure 5:** PLL operation between the data and pilot components in SiGMeP

The parameters of the PLL implemented in SiGMeP are presented in Table 2.

**Table 2:** SiGMeP PLL parameters

PLL parameters	
Loop bandwidth	10 Hz
Discriminator	Atan2 [13]
Loop order	3

### Phase Lock Detector

To assess whether the PLL is locked or not, the Van Dierendonck phase lock detector [14] has been implemented in SiGMeP via the following equations:

$$\cos[2\varepsilon_\varphi] = \frac{NBD}{NBP} \quad (10)$$

where:

- $\varepsilon_\varphi = \varphi_{channel} - \varphi_{rep}$  is the carrier phase estimation,
- and:
- 

$$\begin{cases} NBD = \left( \sum_{k=1}^{M_E} I_p[k] \right)^2 - \left( \sum_{k=1}^{M_E} Q_p[k] \right)^2 \\ NBP = \left( \sum_{k=1}^{M_E} I_p[k] \right)^2 + \left( \sum_{k=1}^{M_E} Q_p[k] \right)^2 \end{cases} \quad (11)$$

where:

- $M_E$  is the number of samples per correlation interval,
- $I_p$  and  $Q_p$  the in-phase and quadrature correlator outputs.

The quantity  $\cos[2\varepsilon_\varphi]$  is close to 1 in good lock conditions. If the detector is below a given threshold, it indicates a PLL loss of lock. To determine this threshold, tests have been conducted, leading to the 0.6 value. The loss of lock detection criterion is thus defined by:

$$\frac{NBD}{NBP} \leq 0.6 \quad (12)$$

**Table 3:** SiGMeP phase lock detector parameters

Phase lock detector parameters	
Type	Van Dierendonck
Threshold	0.6
Correlation interval	10 ms

The lock detector is finally computed for each correlation intervals (see Table 3).

When PLL tracking is used, the phase loss of lock detector is computed in order to know if the PLL is well tracking or not, but all the messages are taken into account in the error rate computation, whatever if the PLL is well tracking or not.

### 4) Received C/N<sub>0</sub> Estimation

The received C/N<sub>0</sub> needs to be estimated for both following reasons. Firstly, this value is used to compute the detection function  $LLR_{AWGN}$  at the decoder input (see previous publications [2] for more details about the detection function). The corresponding average received C/N<sub>0</sub> is estimated in this case for each message. Secondly, the estimated received C/N<sub>0</sub> is used to apply the new methodology described in the next section. In this case, the received C/N<sub>0</sub> is estimated over each 1 second interval.

The received carrier to noise ratio C/N<sub>0</sub> is estimated on the data component by the Van Dierendonck estimator [14] via the following equations:

$$\begin{aligned} \frac{\widehat{C}}{N_0}_{data}(n) \\ = 10 \log \left( \frac{M_E \mu_{NP}(n) - 1}{TI M_E - \mu_{NP}(n)} \right) \quad [dB Hz] \end{aligned} \quad (13)$$

where:

- $M_E$  is the number of samples per correlation interval,
- and:

$$\left\{ \begin{array}{l} \mu_{NP}(n) = \frac{1}{J} \sum_{j=1}^J NP(j) \\ NP(j) = \frac{NBP(j)}{WBP(j)} \\ NBP(j) = \left( \sum_{k=1}^{M_E} I_p[k] \right)^2 + \left( \sum_{k=1}^{M_E} Q_p[k] \right)^2 \\ WBP(j) = \sum_{i=1}^{M_E} (I_p[k]^2 + Q_p[k]^2) \end{array} \right. \quad (14)$$

where:

- $J$  is the number of correlation intervals by the duration used to make the estimation. Here  $J = 1800$  for the  $LLR_{AWGN}$  computation and  $J = 100$  for the new methodology application, with the GPS L1C message and 10 ms as correlation duration.

## II- THE NEW METHODOLOGY FOR DEMODULATION PERFORMANCE IN URBAN ENVIRONMENTS

### 1) Classical Figure of Merit

In the classic method of representing the GNSS signals demodulation performance, inspired by the telecommunications field, the error rate is represented as a function of the received carrier to noise density ratio  $C/N_0$ .

For example, since the essential demodulated data to compute a position are the Clock and Ephemeris Data (CED), the error rate can be computed only on the symbols which correspond to the CED, named the CED error rate.

Figure 6 represents the GNSS signals CED error rate with the classical method in the AWGN propagation channel model. The information bits rates effect (from 25 to 125 bps according to the GNSS signals) as well as the channel code effect are highlighted.

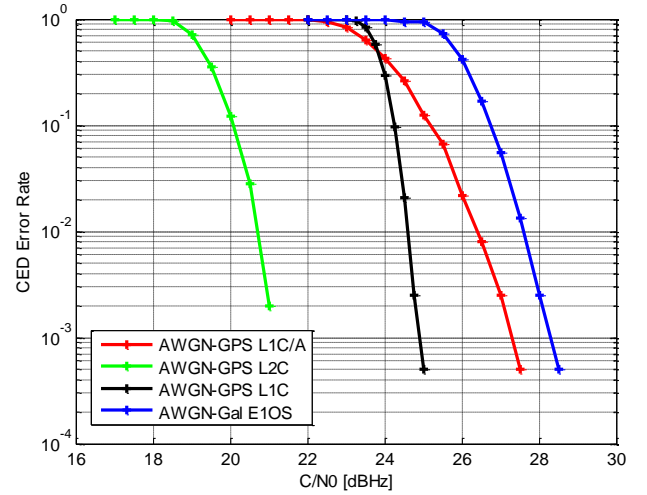

**Figure 6:** Demodulation performance of GNSS signals in the AWGN channel model

However, this way of representing the GNSS signals demodulation performance presents two main limitations:

- The received carrier to noise density ratio  $C/N_0$  is not constant in urban environments,
- Only punctual instead of continuous message demodulations are required because the same CED information set is repeated for a given time interval.

To overcome these limitations, a new methodology to compute and to represent the GNSS signals demodulation performance, adapted to urban environments has been developed; it is detailed in the next sections.

### 2) New Methodology

#### 2) a. Limitation n°1: Fluctuating Received $C/N_0$

##### Description

Contrary to an open environment modelled by an AWGN propagation channel, the urban environment, modelled by a mobile propagation channel, is dynamic. In a dynamic environment, the reception conditions change over time (as can be observed on the time variant property of the channel impulse response  $h$ , equation (2)) because of the user motion and the environmental fluctuations around the user. Therefore, the received signal can be attenuated, can be directly impacted by multipath generated by this obstructed environment and the attenuation and the multipath impact change over time. As a consequence, the useful received signal power  $C$  can fluctuate significantly over time, even for the duration of a message.

It is thus impossible to represent a CED error rate value as a function of a fixed received  $C/N_0$  value in an urban environment.

##### Objectives

In order to solve the 1<sup>st</sup> limitation, the new methodology must:



- Determine a  $C/N_0$  which is constant over one GNSS receiver use,
- Determine a  $C/N_0$  which is representative from an operational point of view.

### Proposition

The theoretical  $C/N_0$  value representing the received direct signal power before channel attenuation, noted as  $C_{pre-urban}$ , can be considered as constant over long periods of time (much longer than the message duration). Therefore, to represent the demodulation performance as a function of the  $C_{pre-urban}/N_0$  seems adapted. Nevertheless, the reader must note that this value is not available at the receiver; it is thus just a theoretical value used to evaluate the message demodulation performance. Moreover, from an operational point of view,  $C_{pre-urban}/N_0$  is constant for a user moving inside an urban environment and for a satellite with a fixed elevation. Therefore, knowing the receiver architecture and interference environment, the demodulation performance can be expressed as a function of the sat elevation in addition to as a function of  $C_{pre-urban}/N_0$ .

In this paper, the GNSS signal demodulation performance in urban environments will be represented by the CED error rate as a function of the theoretical value  $C_{pre-urban}/N_0$ .

### 2) b. Limitation n°2: Messages Don't Need to Be Demodulated Continuously

#### Description

Since only punctual instead of continuous message demodulations are required in GNSS, the classical figure of merit originating from the telecommunications field which considers each received message in the error rate computation is not adapted. In fact, the classical way of representing GNSS signals demodulation performance hides relevant information since it considers that all the received messages, in bad or good reception conditions, must be demodulated for the correct functioning of the GNSS instead of just a few ones, received in good conditions for example. Therefore, the classical demodulation performance fails to cope with the specific GNSS system characteristics with respect to a classical communication system and with the specific characteristics of a received signal in an urban environment.

#### Specific GNSS System Characteristic

For a classical communication system, the receiver must continuously demodulate the received signal. It is not the case for GNSS. Indeed, to compute a position, the receiver only needs to demodulate the ephemeris and clock error correction data (CED). For the GPS L1C signal, an entire CED data set is contained inside the subframe 2. This CED data set is applicable during three hours, but only transmitted during two hours [3]. The emitted CED data is thus invariant during two hours, but applicable one more hour. It means that over two hours,

the GNSS receiver needs just to demodulate one subframe 2 content, to be able to compute a position during at least one hour, if we ignore the Time-To-First-Fix (TTFF) requirement in order to adopt a continued use.

### Specific Characteristic of the Received GNSS Signal in Urban Environments

When a GNSS signal is received into an urban environment, its received amplitude and phase are very distorted and change over time (see equations (3) and (4)). We can thus observe (see figures Figure 7 and Figure 8 obtained using the Perez-Fontan/Prieto model) a series of consecutives states, more or less favorable from a demodulation point of view (see figure Figure 9). For example, the received signal into the intervals [31s, 36s], [37s, 52s] and [59s, 65s] corresponds to an unfavorable state, since the correlator output  $I_p$  cannot clearly determine the emitted bits value, and the interval [17s, 23s] corresponds to a favorable state since the emitted bit value can be clearly determined. Therefore, the instantaneous signal demodulation performance depends on the current signal received conditions.

**Table 4:** Simulation conditions

Simulation Conditions	
Signals	GPS L1C
Channel Model	Perez-Fontan/Prieto
Channel Generation Fs	0.1 ms
Environment	Urban
Database Band	S
Satellite Elevation Angle	40°
Phase Estimation	PLL
$C/N_0$	40 dB-Hz

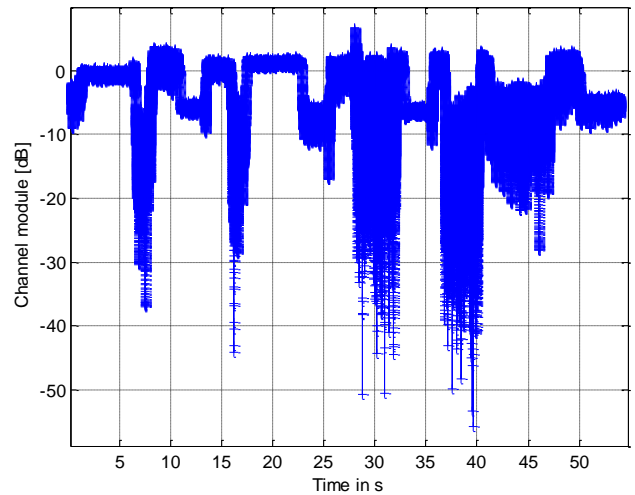

**Figure 7:** The received signal amplitude with the Prieto channel model

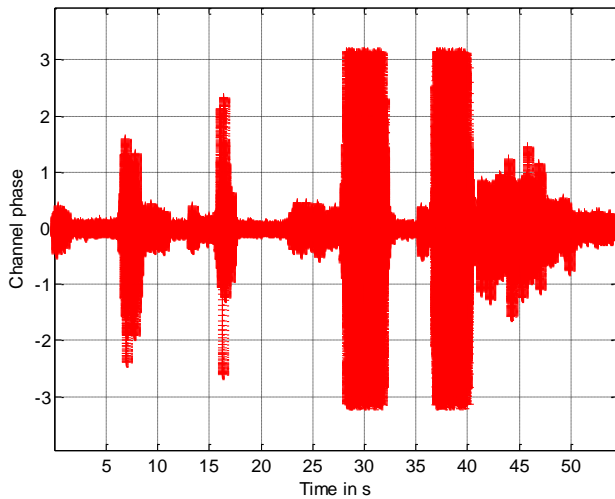

**Figure 8:** The received signal phase with the Prieto channel model

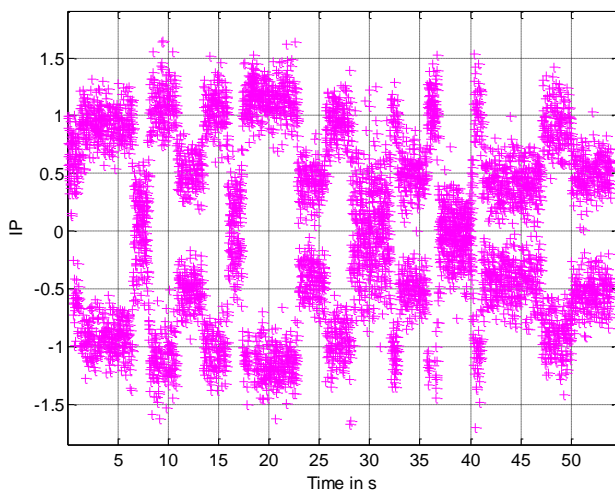

**Figure 9:** The correlator outputs  $I_p$  with the Prieto channel model

### **Objective**

In order to overcome the 2<sup>nd</sup> limitation of the classical figure of merit, the new methodology must rely on the punctual ‘favorable’ received signal conditions together with the non-necessity of continuously demodulating the GNSS message.

### **Proposition**

To provide the demodulation performance for ‘favorable’ reception conditions together with statistical information about the occurrence of these favorable reception conditions.

Indeed, during ‘unfavorable state’ conditions, the demodulation performance can be so bad that less successful demodulations are expected than during ‘favorable state’ conditions. Since it is not necessary to demodulate each received message, it thus seems adapted to specifically look at the performance in ‘favorable state’ conditions. Moreover, statistical values are defined

concerning the ‘favorable states’ in order to inspect if the operational requirements are fulfilled:

- **Minimum guaranteed availability:** it corresponds to the proportion of messages received in a ‘favorable state’ with the associated probability of guaranty (for example at least one message is received in a ‘favorable state’ during a given duration, guaranteed 95% of the time),
- **Average availability:** it corresponds to the proportion of messages received in a ‘favorable state’ in average (for example, in average, 10% of messages needs to be received in a ‘favorable state’).

This method can be summarized as follows.

First, the received signal conditions could be classified into 2 states:

- **Favorable states:** favorable conditions to demodulate the message
- **Unfavorable states:** unfavorable conditions to demodulate the message

Second, the data error rate is computed only for these ‘favorable states’.

Third, statistical results of occurrence are defined for the ‘favorable states’.

### **No Modifications on the receiver demodulation architecture/strategy**

It must be noted that this new methodology DOES NOT involve any change in the receiver demodulation architecture/strategy. The receiver still demodulates each received message, but the way of representing the demodulation performance takes into account only messages in ‘favorable states’ and the associated occurrence, in order to better represent the specific GNSS System characteristics and specific characteristics of a received GNSS signal in an urban environment.

### **Favorable/unfavorable states separation**

The fundamental part of the new proposed methodology consists in defining an adapted ‘favorable state’ for each operational need. In this paper, two criteria of dividing the ‘favorable states’ reception conditions from the ‘unfavorable states’ reception conditions have been inspected:

- The ‘favorable states’ are the Prieto channel ‘GOOD states’ (only for the Perez-Fontan/Prieto propagation channel model use),
- The estimated received  $C/N_0$  is above a threshold. First, the received  $C/N_0$  is estimated for intervals of one second. Second, the minimum estimated received  $C/N_0$  value among all the estimated received  $C/N_0$  of one message is compared with a threshold (e.g. for GPS L1C, 18 estimations of one second interval are made for one message). If the minimum value is

below this threshold, the message is considered to be received in an ‘unfavorable state’. The threshold value depends on the conducted strategy, described in part 2) c.

**Statistical results of occurrence**

Once the criterion to determine a ‘favorable state’ is defined, the ‘favorable states’ can be characterized by their occurrence distribution, representing the proportion of ‘favorable states’ during a given duration. This occurrence distribution is represented through the ‘favorable states’ histogram. Several duration of interest are simulated and for each of them, the number of ‘favorable states’ message is computed. Two key statistical values (illustrated in Figure 10) are then needed to assess the operational performance:

- The probability that no messages are received in ‘favorable states’ during the interest interval, noted as  $P_{0-fav}$  (leading to the minimum guaranteed availability),
- The ‘favorable states’ **average availability** corresponding to the occurrence distribution mean.

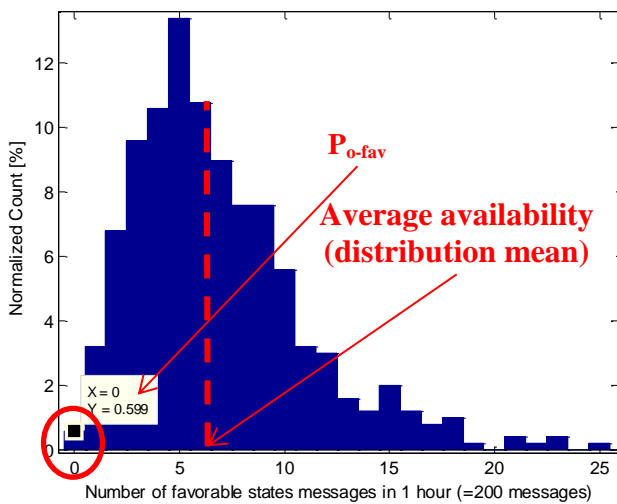

**Figure 10:** Favorable states occurrence distribution and associated statistical values

**2) c. Operational Requirements**

The new methodology has been developed to meet operational requirements. Some operational requirements could be:

- To guarantee that the receiver is able to access information in a given time,  
Example: be able to compute a position continuously
- To guarantee that the information error rate is below a given value,  
Example: CED error rate =  $10^{-2}$
- To guarantee a given information average availability.

Example: to be able to apply “precise positioning corrections”: at least 30% of the total transmitted information must be successfully demodulated

Therefore, the purpose of this new methodology consists in defining the separation between ‘favorable and unfavorable states’ which guarantee the operational requirements fulfillment. To do that, operational requirements are firstly translated into ‘favorable states’ statistical values: distribution of occurrence,  $P_{0-fav}$  and average availability. Then, ‘favorable states’ which fulfill these statistical values must be searched (or, equivalently, the criterion determining the division of the states).

Depending on the operational requirement, and how this requirement is translated into requirements on the ‘favorable states’ statistical values, two strategies can be conducted to apply the new methodology.

**2) d. Two Strategies to Apply the New Methodology**

Two strategies can be conducted to apply this new methodology depending on the desired operational requirements.

**Strategy n°1**

Strategy n°1 is applied for an operational requirement which implies a minimum guaranteed availability. The best demodulation performance for this minimum guaranteed availability is desired (depends on the states’ division criterion). The strategy steps are:

- Step 1: Determining  $P_{0-fav}$  the probability that no ‘favorable state’ message has been received during the duration of interest, according to the minimum guaranteed availability requirement.
- Step 2: Searching for the ‘favorable state’ signal reception condition which induces this  $P_{0-fav}$  probability value.
- Step 3: Calculating the data error rate only for these ‘favorable states’.
- Step 4: Determining the average availability of these ‘favorable states’.

A particular case is to determine whether it is possible to compute a position continuously during the GNSS receiver usage duration. In this case, the data of interest are the CED.

**Strategy n°2**

Strategy n°2 is applied for an operational requirement which implies an average availability. The best demodulation performance for this average availability is desired (depends on the states’ division criterion). The strategy steps are different from strategy n°1:

- Step 1: Searching for the ‘favorable state’ signal reception condition which induces the desired average availability.

- **Step 2:** Calculating the data error rate only for these ‘favorable states’.
- **Step 3:** Determining the probability that no favorable state message has been received during the duration of interest  $P_{0-fav}$  and the guaranteed availability.

### III- RESULTS

In this section, the new methodology proposed to assess the GNSS signals demodulation performance in urban environments has been applied to two different operational requirements examples. Each operational requirements example has been chosen to apply one of the two strategies defined before and to represent a real need. For each conducted strategy, both propagation channel models (described in section I-2)) have been used.

#### 1) Strategy n°1 Application

The operational requirement example chosen to develop the strategy n°1 of the new methodology is:

- To determine if a GPS L1C receiver can guarantee with a probability equal to or higher than 0.95 to obtain enough Clock error corrections and Ephemeris Data (CED) sets, with an error rate equal to  $10^{-2}$  and for a  $C_{pre-urban}/N_0 \leq 30$  dB-Hz, to calculate its position during 4 consecutive hours.

This operational requirement needs then to be interpreted through the methodology, leading to:

- Searching a ‘favorable state’ which provides a CED error rate equal to  $10^{-2}$  for a  $C_{pre-urban}/N_0 \leq 30$  dB-Hz
- Verifying if the minimum number of CED messages, which must be received to allow to continuously calculate the user position for 4 hours when assuming a successful message demodulation, are received in ‘favorable states’. This verification must succeed for 95% of sets of 4 hours.

##### 1) a. With the Perez-Fontan/Prieto Channel Model

###### Step 1: Determining $P_{0-fav \max}$

To determine if the ‘favorable states’ occurrences are enough to compute a position continuously, it is necessary to ensure that the receiver can demodulate at least one received message (we assume that it corresponds to a message received in a ‘favorable state’) from at least four satellites during the same CED set validity period.

For GPS L1C, the emission period of a CED set is equal to two hours, and its validity period is equal to three hours [3]. We define  $t_0$  as the beginning of the CED set emission period (see Figure 11). We assume that at time  $t_0$  the receiver is able to compute a position: the receiver knows the CED sets of at least 4 satellites. To be sure that the receiver can compute a position continuously, since it remains one hour of validity for the CED sets demodulated before  $t_0$ , the receiver needs to demodulate

at least one message from 4 different satellites during the next hour.

- Interval  $(t_0, t_0 + 1h)$  is guaranteed by previous demodulated CED sets.
- Interval  $(t_0 + 1h, t_0 + 2h)$  is guaranteed by CED sets demodulated in interval  $(t_0, t_0 + 1h)$ .
- Interval  $(t_0 + 2h, t_0 + 3h)$  is guaranteed by CED sets demodulated in interval  $(t_0, t_0 + 2h)$ .
- Etc.

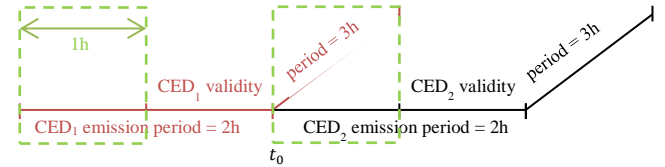

**Figure 11:** CED emission and validity periods diagram for GPS L1C

Considering these notations:

- $P_{final-4h}$ : the probability of receiving in ‘favorable states’ the necessary number of CED messages to allow the user position calculation during 4h from 4 different satellites,
- $P_{1sat-4h}$ : the probability of receiving in a ‘favorable state’ at least 1 message from 1 satellite during the 1<sup>st</sup> hour and at least another message during the 3<sup>rd</sup> hour in a block of 4h,
- $P_{1sat-1h}$ : the probability of receiving in a ‘favorable state’ at least 1 CED message state from 1 satellite during 1h.

Assuming independent emitting satellite propagation channels (15), the probability  $P_{final-4h}$  is equal to:

$$P_{final-4h} = P_{1sat-4h}^4 \quad (15)$$

And assuming independency between emitting satellite propagation channels intervals spaced by 1 hour:

$$P_{final-4h} = (P_{1sat-1h}^2)^4 \quad (16)$$

With:

$$P_{1sat-1h} = 1 - P_{0-fav} \quad (17)$$

And finally,

$$P_{final-4h} = (1 - P_{0-fav})^8 \quad (18)$$

Thus, to fulfil the requirement of the example goal,  $P_{0-fav \max}$  is equal to:

$$P_{final-4h} > 95\% \rightarrow P_{0-fav \max} = 0.64\% \quad (19)$$

###### Step 2: Searching for the favorable states that meet $P_{0-fav \max}$

It is difficult to find the criterion to separate the ‘unfavorable’ from the ‘favorable states’ which provides

the best demodulation performance and which suits the operational requirements as well. Therefore, in this paper a first solution is proposed which exploits the fact that the Perez-Fontan/Prieto propagation channel model is built on two states:

- ‘Good’ for LOS to moderate shadowing, and
- ‘Bad’ for moderate to deep shadowing.

The messages received entirely in ‘Good’ state conditions will be considered as the ‘favorable states’.

In order to ensure that the desired  $P_{0-fav\ max}$  value is respected, the distribution of the ‘favorable states’ messages has been computed with SiGMeP. To do that, the number of messages which are received in a ‘favorable state’ has been calculated during 1 hour (see Figure 10).

The  $P_{0-fav}$  value can be then extracted from this figure: it is the probability that no messages have been received in ‘favorable state’ conditions over one hour. Thus:

$$P_{0-fav} = 0.6\% < P_{0-fav\ max} = 0.64\% \quad (20)$$

The  $P_{final-4h}$  value required in this example is thus respected, meaning that a GPS L1C receiver can guarantee with a probability higher than 0.95 that enough CED sets are received in favorable states to allow the user to continuously calculate its position during 4 hours when assuming successful demodulation.

### **Step 3: Calculating the favorable states CED error rate**

The ‘favorable states’ CED error rate is then computed with SiGMeP with the Perez-Fontan/Prieto propagation channel model, with ideal phase estimation and PLL tracking:

**Table 5: Simulation conditions**

Simulation Conditions	
Signals	GPS L1C
Channel Model	Perez-Fontan/Prieto
Channel Generation Fs	1 ms
Environment	Urban
Database Band	S
Satellite Elevation Angle	40°

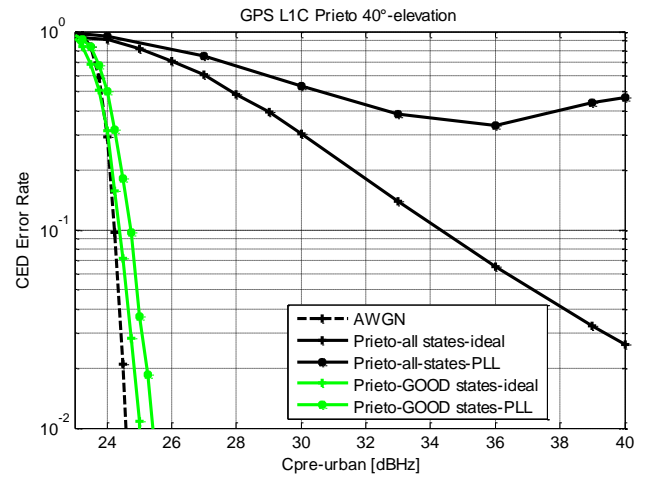

**Figure 12: Favorable states CED demodulation performance with the Prieto model**

Figure 12 represents in black solid lines the GPS L1C demodulation performance considering every received message whatever their reception conditions: ‘favorable states’ or ‘unfavorable states’, as it is made in the classical method. This demodulation performance are really degraded in comparison with the one obtained with the new methodology (green lines) considering only the ‘favorable states’ messages. In fact, the classical methodology is not adapted to a GNSS since each received message does not need to be successfully demodulated. The most interesting information is hidden, which is the demodulation performance corresponding to the minimum number of messages which are needed to be successfully demodulated, taken here as ‘favorable states’ messages.

The floor observed for the PLL tracking case with the classical methodology is suspected to be due to the PLL losses of lock.

It must be remembered that the phase loss of lock detector is computed in order to know if the PLL is well tracking or not, but all the messages are taken into account in the error rate computation, whatever if the PLL is well tracking or not.

It seems thus that it is never possible to demodulate with an error rate equal to  $10^{-2}$  with the classical methodology. In fact it is not adapted to a GNSS, since with the new way of representing the demodulation performance, it can be seen that the GPS L1C CED can be demodulated with an error rate of  $10^{-2}$  for a minimum  $C_{pre-urban}/N_0$  value equal to 25.4 dB-Hz in the PLL tracking configuration in ‘favorable states’ cases. In addition, these ‘favorable states’ CED are available enough to ensure 95% of time the continuous user position computation during 4 consecutive hours.

### **Step 4: Favorable states average availability**

The ‘favorable states’ average availability has been then extracted from Figure 10, it is equal to:

**Table 6: Favorable states average availability**

Favorable states average availability
3.4 %

This information is just complementary to the others. It means that the ‘favorable states’ messages are available in average 3.4% of the time. In fact it is not the essential result since the strategy n°1 requirement concerns the minimum guaranteed availability which has to be enough to ensure a continuous user position computation.

### Further step

The new proposed methodology also allows providing a lower bound on the absolute probability that a receiver is able to continuously compute its position for 4h,  $P_{\text{final-4h bis}}$ . This absolute probability lower bound depends on the  $C_{\text{pre-urban}}/N_0$  and can be calculated as follows (according to (18)):

$$P_{\text{final-4h bis}} = \left( \begin{aligned} &P_{1\text{-fav}} * \left(1 - \frac{\text{CEDER}_C}{N_0}\right) \\ &+ P_{2\text{-fav}} * \left(1 - \frac{\text{CEDER}_C^2}{N_0}\right) \\ &+ \dots \\ &+ P_{200\text{-fav}} * \left(1 - \frac{\text{CEDER}_C^{200}}{N_0}\right) \end{aligned} \right)^8 \quad (21)$$

Finally, as an example, this absolute probability lower bound for a  $C_{\text{pre-urban}}/N_0 = 25$  dB-Hz and ideal phase estimation (leading to CEDER equal to  $10^{-2}$ ), is equal to:

$$P_{\text{final-4h bis}} = 0.95 \quad (22)$$

The SiGMeP simulations through the new methodology in the Perez-Fontan/Prieto propagation channel model, with 4 emitting satellites at  $40^\circ$  of elevation angle, shows that with GPS L1C, the receiver is able to continuously compute its position for 4h, at least 95% of time for a  $C_{\text{pre-urban}}/N_0$  value higher than 25 dB-Hz.

### 1) b. With the DLR Channel Model

The same strategy is then applied with the DLR propagation channel model.

#### Step 1: Determining $P_{0\text{-fav max}}$

Since this  $P_{0\text{-fav max}}$  value only depends on the emission and validity interval of the transmitted GNSS signal CED set, the propagation channel model has no impact on it. Therefore:

$$P_{\text{final-4h}} > 95\% \rightarrow P_{0\text{-fav max}} = 0.64\% \quad (23)$$

#### Step 2: Searching for the favorable states that meet $P_{0\text{-fav}} < P_{0\text{-fav max}}$

The aim of this step consists in determining a separation between ‘favorable’ and ‘unfavorable states’ which ensures that the probability that no messages are received in ‘favorable states’ during the interest interval  $P_{0\text{-fav}}$  is lower than  $P_{0\text{-fav max}}$ .

It is difficult to find the best criterion to separate the ‘unfavorable’ from the ‘favorable states’ and the first solution used for the Perez-Fontan/Prieto propagation channel model cannot be used with the DLR model, since ‘good’ and ‘bad’ states do not longer exist in the DLR model generation. The separation between ‘favorable’ and ‘unfavorable states’ has thus been made by applying the 2<sup>nd</sup> criterion of section 2.b): through the estimation of the received  $C/N_0$ .

First, the received  $C/N_0$  is estimated for intervals of 1 second. Second, the minimum estimated received  $C/N_0$  value among all the estimated received  $C/N_0$  of one message is selected. Third, the distribution of the degradation between  $C_{\text{pre-urban}}/N_0$  and the selected  $C/N_0$  value is computed (see Figure 12). Since this degradation depends on the  $C_{\text{pre-urban}}/N_0$  input value, this process is made for each  $C_{\text{pre-urban}}/N_0$ .

$$\text{threshold} = f(C_{\text{pre-urban}}/N_0, P_{0\text{-fav}}) \quad (24)$$

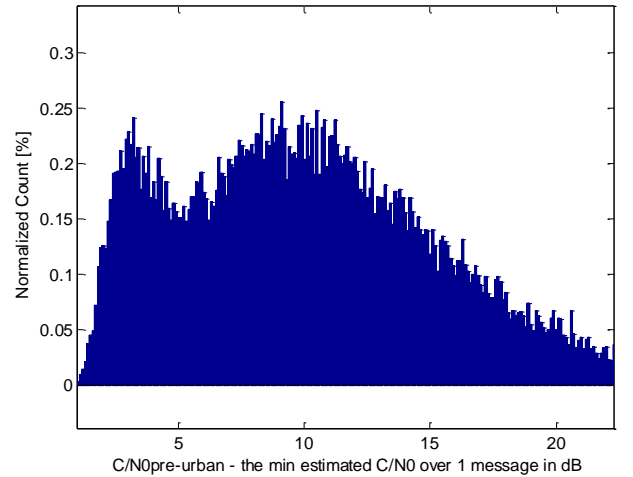
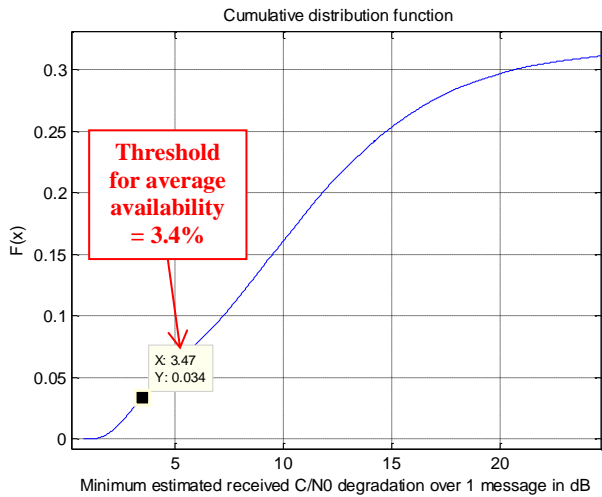

**Figure 13:** Distribution of the degradation between the  $C_{\text{pre-urban}}/N_0$  value and the minimum estimated received  $C/N_0$  over 1 message, for  $C_{\text{pre-urban}}/N_0 = 25$  dB-Hz and ideal phase estimation with the DLR model

From this figure, a threshold is determined. The messages for which the degradation is below this threshold will be considered as ‘favorable states’ messages.

Since the separation between ‘favorable states’ and ‘unfavorable states’ made for the Perez-Fontan/Prieto propagation channel model has implied an average availability equal to 3.4%, this is this value which will be used for the DLR model ‘favorable states’ definition. It means that the threshold value is chosen to ensure

‘favorable states’ messages are available 3.4% of the time in average.

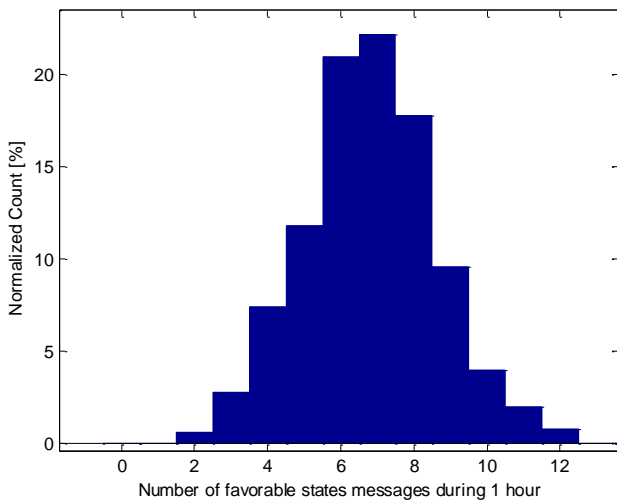

**Figure 14:** Cumulative distribution function of the degradation between the  $C_{pre-urban}/N_0$  value and the minimum estimated received  $C/N_0$  over 1 message, for  $C_{pre-urban}/N_0 = 25$  dB-Hz and ideal phase estimation with the DLR model

In Figure 14 for example, the degradation threshold value corresponding to an average availability of 3.4% is equal to 3.47 dB. It induces that a received message for which the minimum estimated received  $C/N_{0min}$  fulfills this following condition (25) is considered as a ‘favorable state’ message.

$$C/N_{0min} > C_{pre-urban}/N_0 + threshold \quad (25)$$

Then, it remains to ensure that  $P_{0-fav} < P_{0-fav max}$ . The distribution of the ‘favorable states’ messages has been computed with SiGMeP. To do that, the number of messages which are received in a ‘favorable state’ has been calculated during 1 hour and has been divided by the total number of messages sent in the same 1 hour (see Figure 15).



**Figure 15:** Favorable states messages over 1 hour distribution with 3.4% of average availability, for  $C_{pre-urban}/N_0 = 25$  dB-Hz and ideal phase estimation, with the DLR model

The  $P_{0-fav}$  value can be then extracted from this figure: it is the probability that no messages have been received in ‘favorable state’ conditions over one hour. Thus:

$$P_{0-fav} = 0\% < P_{0-fav max} = 0.64\% \quad (26)$$

The  $P_{final-4h}$  value required in this example is thus respected, meaning that a GPS L1C receiver can guarantee with a probability of 1 that enough CED sets are received in favorable states to allow the user to continuously calculate its position during 4 hours when assuming successful demodulation.

### Step 3: Calculating the favorable states CED error rate

The ‘favorable states’ CED error rate is then computed with SiGMeP with the DLR propagation channel model, with ideal phase estimation and PLL tracking:

**Table 7:** Simulation conditions

Simulation Conditions	
Signals	GPS L1C
Channel Model	DLR
Channel Generation Fs	1 ms
Environment	Urban
Satellite Elevation Angle	40°
Satellite Azimuth Angle	30°

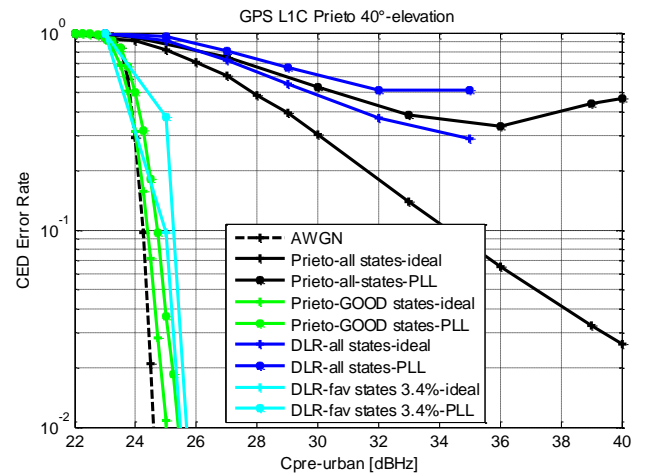

**Figure 16:** Favorable states CED demodulation performance with the DLR model

As for the Perez-Fontan/Prieto propagation channel model case, the demodulation performance with the classical methodology (dark blue lines) are really degraded in comparison with the one obtained with the new methodology (light blue lines) considering only the ‘favorable states’ messages. It seems thus that it is never possible to demodulate with an error rate equal to  $10^{-2}$  with the classical methodology. In fact it is not adapted to a GNSS, since with the new way of representing the

demodulation performance, it can be seen that the GPS L1C CED can be demodulated with an error rate of  $10^{-2}$  for a minimum  $C_{pre-urban}/N_0$  value equal to 25.7 dB-Hz in the PLL tracking configuration in ‘favorable states’ cases. In addition, these ‘favorable states’ CED are available enough to ensure 100% of time the continuous user position computation during 4 consecutive hours.

**Further step**

Finally, the absolute probability lower bound for a  $C_{pre-urban}/N_0 = 25$  dB-Hz and ideal phase estimation (leading to CEDER approximately equal to  $10^{-2}$ ), is equal to:

$$P_{final-4h\ bis} = 1 \tag{27}$$

The SiGMeP simulations through the new methodology in the DLR propagation channel model, with 4 emitted satellites at 40° of elevation angle and 30° of azimuth angle, shows that with GPS L1C, the receiver is able to continuously compute its position for 4h, 100% of time for a  $C_{pre-urban}/N_0$  value higher than 25 dB-Hz.

**2) Strategy n°2 Application**

The operational requirement example chosen to develop the strategy n°2 of the new methodology is:

- To determine if a receiver is able to demodulate 10% of time the GPS L1C **subframe 3** with an error rate equal to  $10^{-2}$  and for a  $C_{pre-urban}/N_0 \leq 30$  dB-Hz.

This operational requirement needs then to be interpreted through the methodology, leading to:

- Searching a ‘favorable state’ which provides an average availability equal to 10%,
- Verifying if the GPS L1C subframe 3 demodulation process in ‘favorable states’ provides a Subframe Error Rate =  $10^{-2}$  for a  $C_{pre-urban}/N_0 \leq 30$  dB-Hz.

**2) a. With the Perez-Fontan/Prieto Channel Model**

**Step 1: Searching for the favorable states that meet average availability = 10%**

The aim of this step consists in determining a division between ‘favorable’ and ‘unfavorable states’ which ensures that the ‘favorable states’ average availability is equal to 10%. The division between ‘favorable’ and ‘unfavorable states’ has been made through the estimation of the received  $C/N_0$  as detailed in 1) b.

The threshold is determined ensuring the desired average availability equal to 10%.

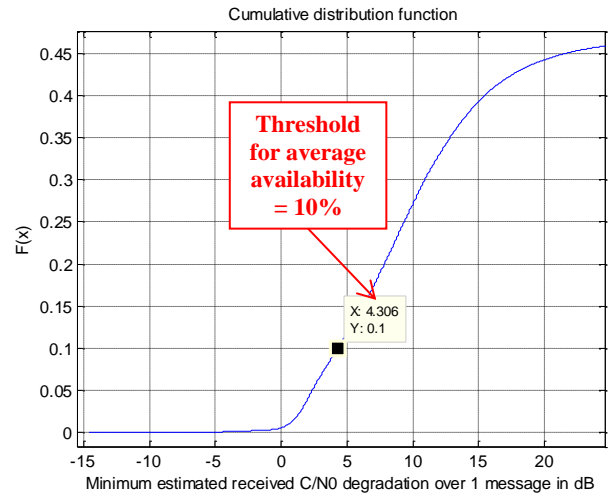

**Figure 17:** Cumulative distribution function of the degradation between the  $C_{pre-urban}/N_0$  value and the minimum estimated received  $C/N_0$  over 1 message, for  $C_{pre-urban}/N_0 = 25$  dB-Hz and ideal phase estimation, with the Prieto model

In Figure 17 for example, the degradation threshold value corresponding to an average availability of 10% is equal to 4.306 dB for  $C_{pre-urban}/N_0$  equal to 25 dB-Hz. It induces that a received message for which the minimum estimated received  $C/N_{0min}$  fulfills this following condition (28) is considered as a ‘favorable state’ message, the threshold depending on the  $C_{pre-urban}/N_0$  value.

$$C/N_{0min} > C_{pre-urban}/N_0 + threshold \tag{28}$$

**Step 2: Calculating the favorable states subframe 3 error rate**

The ‘favorable states’ subframe 3 error rate is then computed with SiGMeP with the Perez-Fontan/Prieto propagation channel model, with ideal phase estimation and PLL tracking:

**Table 8:** Simulation conditions

Simulation Conditions	
Signals	GPS L1C
Channel Model	Perez-Fontan/Prieto
Channel Generation Fs	1 ms
Environment	Urban
Database Band	S
Satellite Elevation Angle	40°



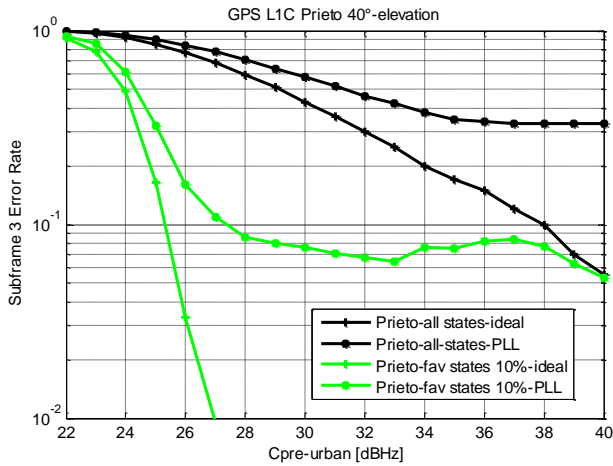
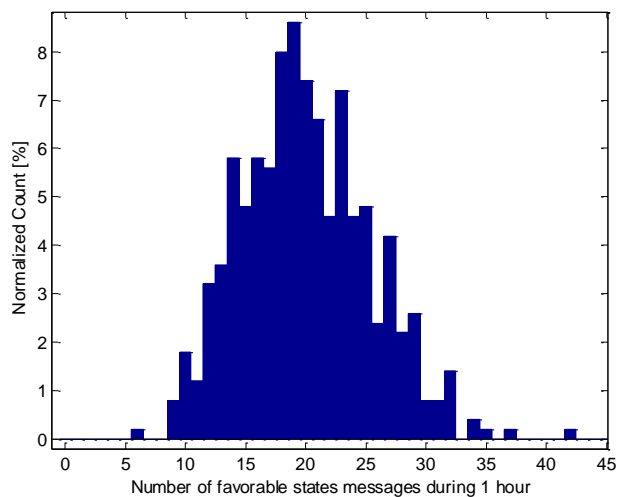

**Figure 18:** Favorable states subframe 3 demodulation performance with the Prieto model

The floor observed for the PLL tracking case with the new methodology is lower than the floor obtained with the classical methodology but still existing. It seems that the ‘favorable states’ defined in this part according to the estimated received  $C/N_0$  value is not really adapted, since the essential information is still hidden. This way of separating ‘favorable states’ from ‘unfavorable states’ does not specifically tackle the PLL losses of lock, which seems to be an essential parameter of successful demodulation.

**Step 3: Determining  $P_{0-fav}$  and the guaranteed availability**

Then, the objective is to determine the availability which is really guaranteed 97% of the time. To do that, the ‘favorable states’ messages occurrence distribution is computed. This figure allows providing statistical results about the ‘favorable state’ messages occurrence very interesting and complementary to the first results. Indeed, the demodulation performance associated to ‘favorable state’ messages available in average 10% of time can be completed by: the probability that this average availability is equal to 10% and the guaranteed availability 97% of time.



**Figure 19:** Favorable states messages over 1 hour distribution, for  $C_{pre-urban}/N_0 = 25$  dB-Hz and ideal phase estimation with the Prieto model

Statistical results are thus extracted from Figure 19:

**Table 9: Favorable states statistical results**

Statistical results	
<b>Average availability</b>	= 10% guaranteed 51% of the time
<b><math>P_{0-fav}</math></b>	0
<b>Guaranteed availability</b>	= 5.5% guaranteed 96% of the time

**2) b. With the DLR Channel Model**

**Step 1: Searching for the favorable states that meet average availability = 10%**

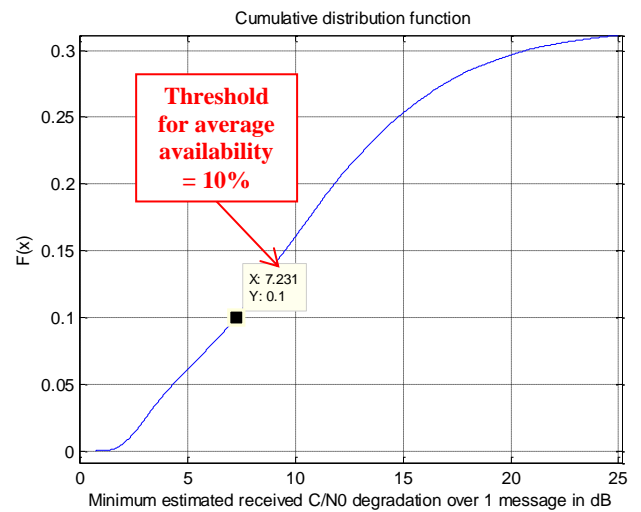
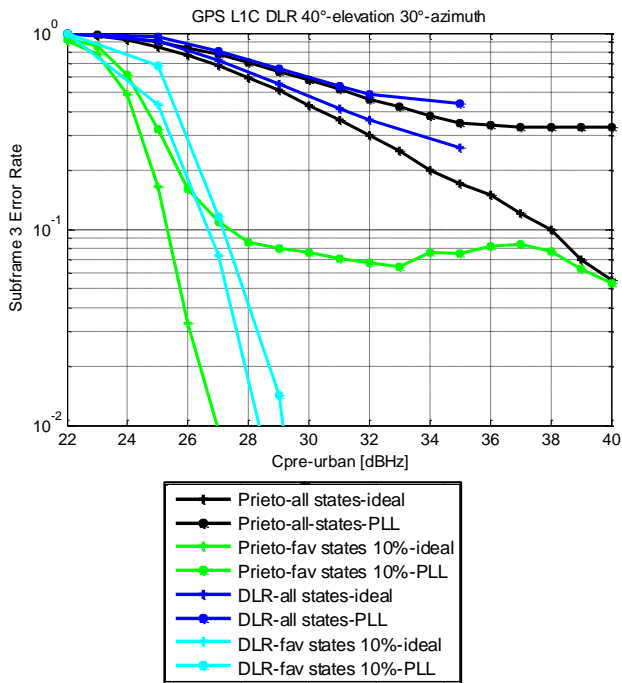

**Figure 20:** Cumulative distribution function of the degradation between the  $C_{pre-urban}/N_0$  value and the minimum estimated received  $C/N_0$  over 1 message, for  $C_{pre-urban}/N_0 = 25$  dB-Hz and ideal phase estimation, with the DLR model

**Step 2: Calculating the favorable states subframe 3 error rate**

**Table 10: Simulation conditions**

Simulation Conditions	
Signals	GPS L1C
Channel Model	DLR
Channel Generation Fs	1 ms
Environment	Urban
Satellite Elevation Angle	40°
Satellite Azimuth Angle	30°



**Figure 21:** Favorable states subframe 3 demodulation performance with the DLR model

The floor observed for the PLL tracking case with the classical methodology and with the new methodology for the Perez-Fontan/Prieto propagation channel model does not exist with the new methodology and the DLR model. It can be supposed that the PLL losses of lock are less present when the DLR propagation channel model is generated instead of the Perez-Fontan/Prieto propagation channel model.

**Step 3: Determining  $P_{0-fav}$  and the guaranteed availability**

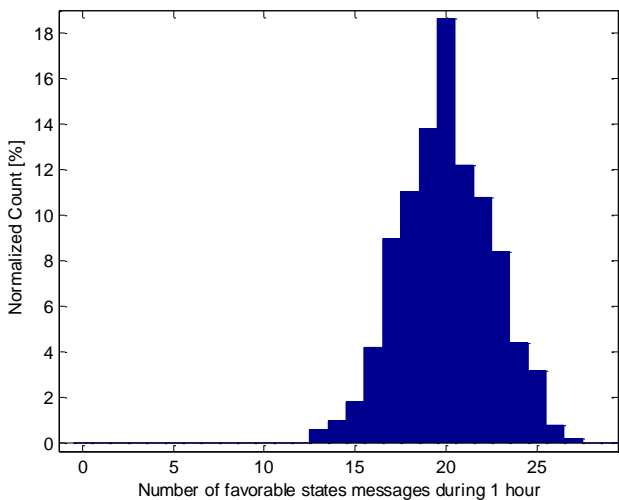

**Figure 22:** Favorable states messages over 1 hour distribution, for  $C_{pre-urban}/N_0 = 25$  dB-Hz and ideal phase estimation with the DLR model

**Table 11: Favorable states statistical results**

<b>Average availability</b>	= 10% guaranteed 59% of the time
<b><math>P_{0-fav}</math></b>	0
<b>Guaranteed availability</b>	= 8% guaranteed 97% of the time

**IV- CONCLUSIONS AND PERSPECTIVES**

The classical methodology usually used to provide the GNSS signals demodulation performance is not adapted for urban environments. In fact, two main limitations have been underlined: the fluctuating received  $C/N_0$  in urban areas and an important characteristic of the GNSS which is not taken into account concerning the messages which don't need to be demodulated continuously. A new methodology has thus been proposed, adapted to urban environments and meeting operational requirements: to provide the demodulation performance for 'favorable' reception conditions together with statistical information about the occurrence of these favorable reception conditions. According to the operational requirement, two strategies have thus been implemented. In this paper, the particular case of the GPS L1C signal has been developed.

It has been showed that the demodulation performance obtained with the classical methodology are really degraded in comparison with the one obtained with the new methodology considering only the 'favorable states' messages. In fact, the most interesting information is hidden, which is the demodulation performance corresponding to the minimum number of messages which are needed to be successfully demodulated, taken here as 'favorable states' messages.

However the 'favorable states' messages determination is not easy and still needs to be more investigated. In particular, it seems more representative of reality if the parameter used to make the separation between 'favorable states' and 'unfavorable states' takes into account the detected PLL losses of lock.

Moreover, the new methodology has only been developed for a continued usage in this paper, without constraints concerning the TTFF, whereas it is relevant information. Thus, this aspect remains to be investigated.

**REFERENCES**

[1] M. Roudier, A. Garcia-Pena, O. Julien, T. Grelier, L. Ries, C. Poulliat, M.-L. Boucheret, and D. Kubrak, "New GNSS Signals Demodulation Performance in Urban Environments," in *Proceedings of the 2014 International Technical Meeting of The Institute of Navigation*, 2014.

[2] M. Roudier, C. Poulliat, M.-L. Boucheret, A. Garcia-Pena, O. Julien, T. Grelier, L. Ries, and D. Kubrak, "Optimizing GNSS Navigation Data

- Message Decoding in Urban Environment,” presented at the ION PLANS 2014, 2014.
- [3] US Government, “INTERFACE SPECIFICATION IS-GPS-800 Navstar GPS Space Segment/User Segment L1C Interface.” Sep-2012.
- [4] F. Perez-Fontan, M. A. Vázquez-Castro, S. Buonomo, J. P. Poyares-Baptista, and B. Arbesser-Rastburg, “S-band LMS propagation channel behaviour for different environments, degrees of shadowing and elevation angles,” *IEEE Trans. Broadcast.*, vol. 44, no. 1, pp. 40–76, 1998.
- [5] F. P. Fontan, M. Vazquez-Castro, C. E. Cabado, J. P. Garcia, and E. Kubista, “Statistical modeling of the LMS channel,” *IEEE Trans. Veh. Technol.*, vol. 50, no. 6, pp. 1549–1567, 2001.
- [6] R. Prieto-Cerdeira, F. Perez-Fontan, P. Burzigotti, A. Bolea-Alamañac, and I. Sanchez-Lago, “Versatile two-state land mobile satellite channel model with first application to DVB-SH analysis,” *Int. J. Satell. Commun. Netw.*, vol. 28, no. 5–6, pp. 291–315, 2010.
- [7] J. G. Proakis and M. Salehi, *Digital communications*. Boston: McGraw-Hill, 2008.
- [8] A. L. Alexander Steingass, “Measuring GALILEO’s Multipath Channel.”
- [9] DLR, “Implementation of the Land Mobile Satellite Channel Model - Software Usage.” 2007.
- [10] DLR, “Land Mobile Satellite Channel Model - Interface Control Document.” 2008.
- [11] A. Lehner and E. Steingass, “A.: “A novel channel model for land mobile satellite navigation,” in *Institute of Navigation Conference ION GNSS 2005*, pp. 13–16.
- [12] A. Steingaß and A. Lehner, “Measuring the Navigation Multipath Channel – A Statistical Analysis,” in *Proceedings ION GNSS 2004*, Long Beach, California, 2004, vol. Session C3.
- [13] E. D. Kaplan and C. J. Hegarty, *Understanding GPS: Principles and Applications*. Artech House, 2005.
- [14] B. W. Parkinson and J. J. Spilker Jr., *Global Positioning System: Theory and Applications Volume I*, vol. 163. Paul Zarchan, 1996.